

Studies on Chitosan Extraction and Its Biomedical Properties

Alef Mustafa

UMF "Carol Davila" Bucharest, Faculty of
Pharmacy, Romania

Rodica Sîrbu

"Ovidius" University of Constanța, Faculty of
Pharmacy, Constanta, Romania

Abstract

Chitin and chitosan are natural biopolymers that are included in the novel families of biological macromolecules. Chitosan is the main derivative of chitin, and research upon the characteristics and properties of these molecules has become increasingly evident and important. It was reported that the main and potential applications of these polymers as well as their derivatives are more than 200. These applications include biomedicine, pharmacy, agriculture, biotechnology, cosmetics. In the last years, especially in the pharmaceutical and medical fields chitosan has received considerable attentions as a functional, renewable, nontoxic and biodegradable biopolymer for diverse applications. The recent efforts of the scientists concentrated on the methods of preparation of chitin from raw material, on processing chitosan, as well as on the chemical and biological properties that help increase solubility in aqueous solutions.

Keywords: chitosan derivatives, chitin, chitosan, biomedicine, biopolymer

1. Introduction

After cellulose, chitin is known to be the next most abundant natural biopolymer in the world. Chitin is naturally found in the exoskeleton of crustaceans, insects' cuticles, mainly in the outside structure of a large number of invertebrates and cell walls of fungi. It was reported that the main and potential applications of these polymers as well as their derivatives are more than 200 [1]. Chitin is described as a white, hard, inelastic, nitrogenous polysaccharide. The main derivative of chitin, chitosan is naturally present only in some fungi, such as *Mucoraceae* [2]. Like cellulose, it functions naturally as a structural polysaccharide. Chitin is highly hydrophobic and is insoluble in water and most organic solvents [3]. It is soluble in hexafluoroisopropanol, hexafluoroacetone, chloroalcohols in conjugation with

aqueous solutions of mineral acids [4]. Chitosan, the deacetylated product of chitin, is soluble in dilute acids such as acetic acid, formic acid.

Chitin and chitosan are presented as a family of linear polysaccharides consisting of varying amounts of β (1 \rightarrow 4) linked residues of N-acetyl-2-amino-2-deoxy-D-glucose and 2-amino-2-deoxy-D-glucose residues [4]. In other words, chitin is well known to consist of 2-acetamido-2-deoxy-D-glucose through a β -(1 \rightarrow 4) linkage and chitosan is a copolymer consisting of β -(1 \rightarrow 4)-2-acetamido-D-glucose and β -(1 \rightarrow 4)-2-amino-D-glucose units. The structures of cellulose, chitin and chitosan are shown in Fig. 1.

In the field of medicine, besides the application as artificial skin, absorbable surgical suture, and a wound healing accelerator, chitosan has been used to form new physiological materials because of its remarkable properties, such as antimicrobial, antioxidative, antitumor effects [5]. These applications are dependent on the chemical structure and the molecular size and are limited by the polysaccharides high molecular weight and low solubility in acid-free aqueous media, that makes it highly viscous.

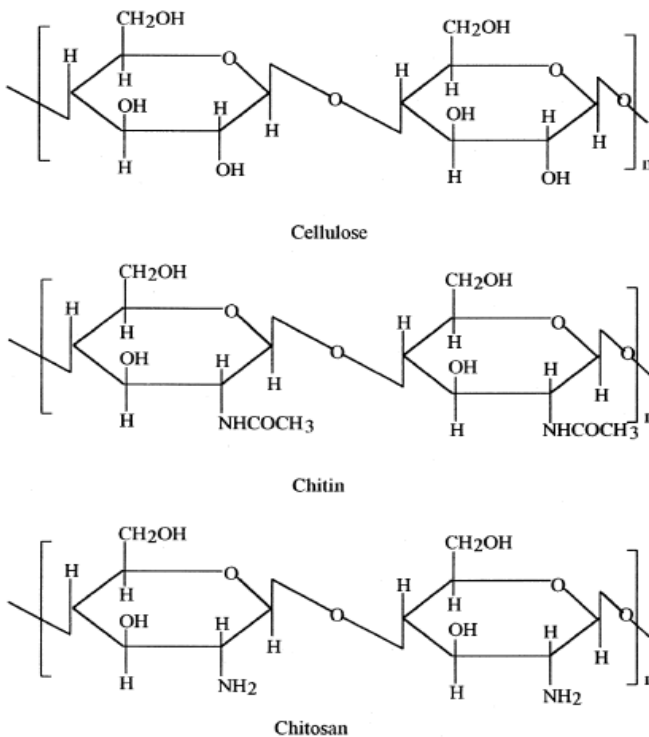

Fig. 1. Structures of cellulose, chitin and chitosan.

In the field of medicine, besides the application as artificial skin, absorbable surgical suture, and a wound healing accelerator, chitosan has been used to form new physiological materials because of its remarkable properties, such as antimicrobial,

antioxidative, antitumor effects [5]. These applications are dependent on the chemical structure and the molecular size and are limited by the polysaccharides high molecular weight and low solubility in acid-free aqueous media, that makes it highly viscous.

For a better use of chitosan the efficient and responsible utilization of marine biomass resources is an environmental priority in the last years.

This paper focuses on the preparation of chitosan from chitin using various chemical processes, in combination with pharmaceutical and biomedical applications especially focusing on the antioxidative and antimicrobial effects of these biomaterials based on recent literature.

2. Research Methods

As mentioned above, chitin is easily obtained from crab or shrimp shells and fungal mycelia. Chitin production is associated with food industries such as shrimp canning.

The methods of preparation include Chitin Extraction, Chitin Deacetylation and Chitosan Depolymerization.

2.1 Chitin Extraction

In order to obtain chitin from raw material such as crab and shrimp shells and fungal mycelia, some successive processes must be followed. Primarily, the raw material is washed and grinded. Chitin is extracted by acid treatment using HCl, to dissolve the calcium carbonate followed by alkaline extraction with NaOH to dissolve the proteins and by a depigmentation step, the bleaching using NaOCl to obtain a colourless product mainly by removing the astaxantine.

A schematic representation of the processes to prepare chitin and chitosan from raw material is shown in Scheme 1.

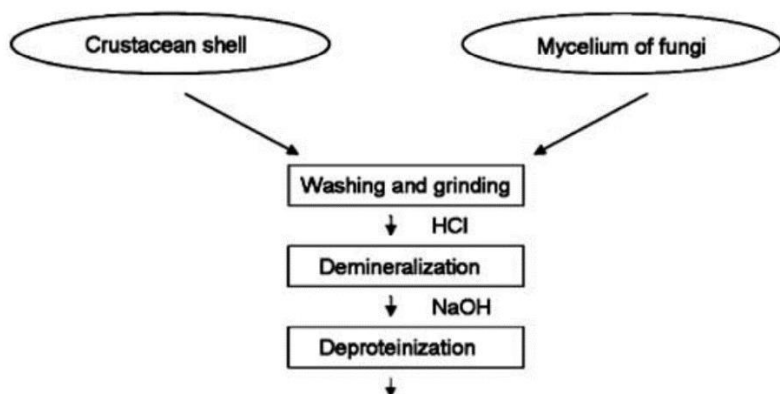

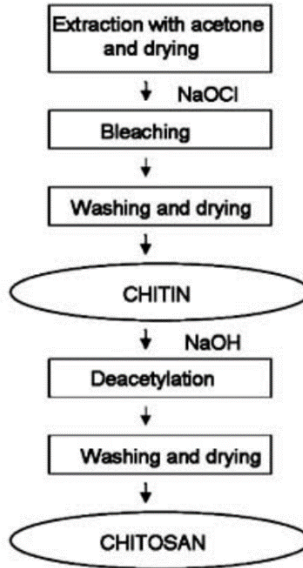

Scheme 1. Preparation of chitin and chitosan from raw material

It was discovered that numerous taxonomic groups present chitin which is divided into three crystal types: α , β and γ type. α -chitin is produced by isolation from marine crustaceans. In consequence of this food processing, large quantities of waste are available, as by-products. β -chitin is produced using squid pens. It was demonstrated that α -chitin is the most common polymorphic form and the majority of studies were made on α -chitin and a very few on γ -chitin. This is because the γ -chitin form is considered by some researchers to be a distorted version of either one of the other forms, and not a proper third polymorphic form [2].

If we look at the structures, the α -chitin form has the chains arranged in sheets that have the same sense. In the β -chitin form the adjacent sheets along the c axis have the same sense and they are parallel, while in γ -chitin, the third sheet has the opposite sense to the two in front [2].

A schematic representation of the three structures is shown in Fig. (2).

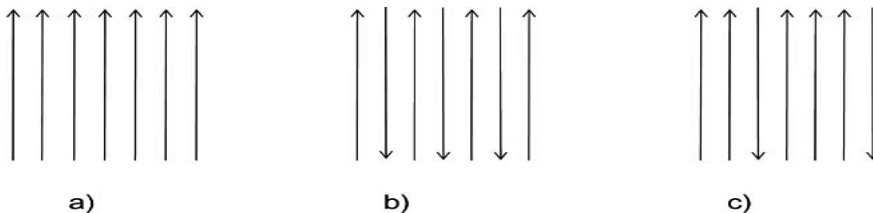
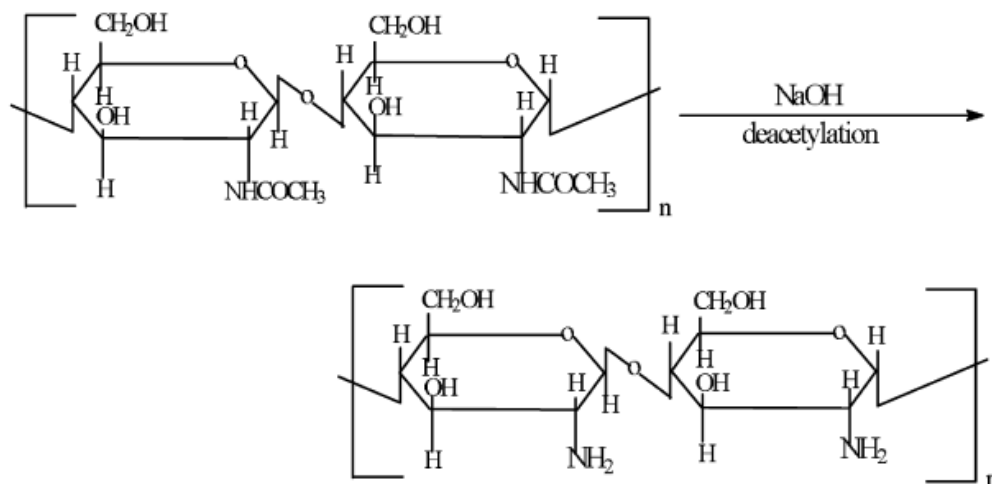

Fig. 2. Three polymorphic configurations of Chitin (A) α -chitin, (B) β -chitin and (C) γ -Chitin

It was observed that crustacean shells have a content of 30-40% proteins, 30-50% calcium carbonate, and 20-30% chitin and pigments of a lipidic nature such as carotenoids. These proportions vary with season and with species [6].

2.2 Chitin Deacetylation

By using severe hydrolysis treatment on the acetamide groups of chitin, because of the resistance imposed on the groups by the *trans* arrangement of the C2-C3 substituents in the sugar ring, chitosan is prepared [7]. Usually, the production of chitosan–glucan complexes is associated with fermentation processes, similar to those for the production of citric acid from *Aspergillus niger*, *Mucor rouxii*, and *Streptomyces*. These processes involve alkali treatment yielding chitosan–glucan complexes. The removal of the protein and the deacetylation of the chitin are simultaneous. There is a situation where soluble glycans are removed, depending on the alkali concentration [8]. As presented above, crustacean shells consist of high concentrations of proteins and calcium carbonate, so the processing of these shells requires the removal of these components. The resulting chitin is deacetylated in 40% sodium hydroxide at 120° C for 1–3 h. This treatment produces 70% deacetylated chitosan (Scheme 2) [1].



Scheme 2. Chitin deacetylation

2.3 Chitosan Depolymerization

It was demonstrated that chitosan has a low solubility and a high viscosity, properties that limit its use in various applications. By using hydrolysis on the polymer chain can result in low molecular weight (Mw) chitosans and oligomers which have been found more useful in some applications, due to the small size. Chitosan depolymerization can be carried out in 3 ways: chemically, enzymatically or physically. Chemical depolymerization (Fig. 3) is mainly carried out by acid hydrolysis using HCl or by oxidative reaction using HNO₂ and H₂O₂ [9].

DD (degree of deacetylation), Mw (molecular weight), polydispersity and crystallinity are the main parameters affecting the polymer properties. Recently, it has been reported that the DD and average Mw are one of the most important chemical characteristics, which could influence the performance of chitosan in many of its applications and play a significant role in the biochemical and biopharmacological significance of chitosan [10].

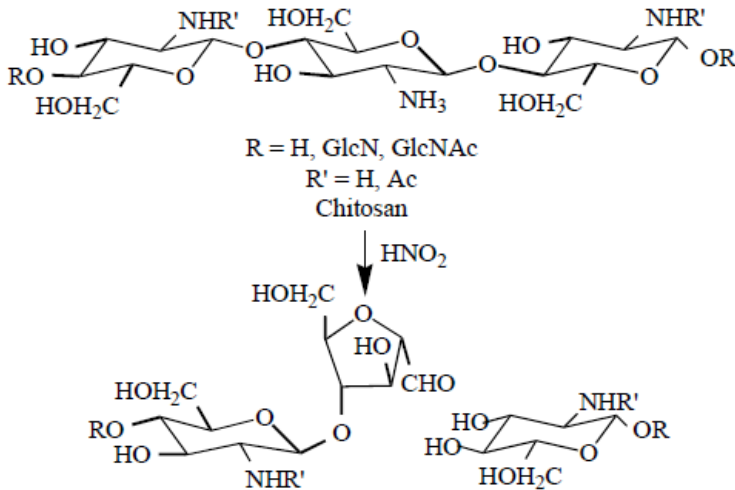

Fig. 3. Chemical depolymerization of chitosan.

3. Biomedical Properties

3.1 Antimicrobial Activity

Over the last years the antimicrobial activity of chitin, chitosan, and their derivatives against bacteria, yeast, and fungi, has received very much attention. It was discovered that chitosan inhibits microbial cells by two mechanisms. The first mechanism refers to an interaction with the anionic groups on the cell surface, causing the formation of an impermeable layer around the cell. Due to its polycationic nature it prevents the transport of essential solutes. Researchers demonstrated that the site of action is the outer membrane of gram negative bacteria, by using electron microscopy [11]. The second mechanism involves the permeation into the cell nucleus in order to inhibit the RNA and protein synthesis. A group of researchers, Liu *et al.* have observed labelled chitosan oligomers with Mw from 8 to 5 kDa inside the *E. coli* cell and they showed good antibacterial activities [12]. In this case the Mw is the decisive property, as is shown in Table 1.

Table 1. Influence of Chitosan DD and Mw on Antimicrobial Activity

Physico-Chemical Property	Effect on Antimicrobial Activity
↑ DD	↑ electrostatic binding to membrane
	↑ permeabilizing effect
↑ Mw	↓ permeation into the cell nucleus

3.2 Antioxidative Activity

When compared with commercial antioxidants, the results obtained with chitosan were significant and comparable, due to chitosan's scavenging capacity against different species.

In one study, a sample was prepared from crab shell chitin with DD of 90,75 and 50% and was evaluated based on the ability to scavenge 1,1-diphenyl-2-picrylhydrazyl (DPPH) radical, hydroxyl radical, superoxide radical and alkyl radical. The results showed that DD is the principal property that is responsible for this activity, because chitosan with higher DD exhibited the highest scavenging activity [13].

In another study, there were used chitosans of different sizes and sulphate derivatives of chitosan and were assayed against superoxide and hydroxyl radicals. The results revealed a negative correlation between chitosan Mw and activity (Table 2). It was also shown that the chitosan sulphated derivatives presented a stronger scavenging effect on peroxide radicals. On the other hand, the chitosan of lowest Mw showed more considerable ferrous ion-chelating potency than others [14]. This property, the chelation of metal ions is one of the reasons why chitosan may be considered a potential natural antioxidant for prolonging shelf life by stabilizing lipid containing foods. Chitosan may impregnate a retard action on lipid oxidation and so eliminating the prooxidant activity of the foods [15].

Table 5. Influence of Chitosan DD and Mw on Antioxidative Activity

Physico-Chemical Property	Effect on Antioxidant Activity
↑ DD	↑ scavenging effect
↑ Mw	↓ radical scavenging effect
	↓ ion-chelating potency

Conclusions

Chitin and chitosan present a great variety of properties, allowing them to have a large number of applications, but, at the same time, the very complex behaviour of these polymers is difficult to control. In fact, not every chitin or chitosan sample can be used for the same applications. That is why a complete characterization of the samples is needed. In general, a poor characterization of the polymers is carried out which

makes it very difficult to compare results and to establish relationships between the physiological behaviour of chitin and chitosan and their properties. Even so, from data in the literature it is possible to find and to give general recommendations regarding the properties of chitin and chitosan for a specific application. Many sources reported that the origin of chitin influences not only its crystallinity and purity but also its polymer chain arrangement, and hence its properties.

References

- [1] Acosta N, Jimenez C, Borau V, Heras A., Extraction and characterization of chitin from crustaceans. *Biomass Bioenerg* 1993; 5(2): 145-53.
- [2] Helander I, Nurmiäho-Lassila E, Ahvenainen R, Rhoades J, Roller S. Chitosan disrupts the barrier properties of the outer membrane of Gram-negative bacteria. *Int J Food Microbiol* 2001; 71: 235-44.
- [3] Horton D, Lineback DR., N-deacetylation, chitodan from chitin. In: Whistler RL, Wolfson ML, Eds. *Methods in Carbohydrate Chemistry*. New York: Academic Press 1965: 403.
- [4] Inmaculada Aranaz, Marian Mengibar, Ruth Harris, Inés Paños, Beatriz Miralles, Niuris Acosta, Gemma Galed and Ángeles Heras, Functional Characterization of Chitin and Chitosan. *Current Chemical Biology*, 2009, 3, 203-230
- [5] Jeon, Y.J.; Shahidi, F.; Kim, S.K., Preparation of chitin and chitosan oligomers and their application in physiological functional foods. *Food Rev. Int.* 2000, 16, 159-176
- [6] Kumar MNVR, A review of chitin and chitosan applications. *React Funct Polym* 2000; 46: 1-27.
- [7] Liu X, Yun L, Dong Z, Zhi L, Kang D., Antibacterial action of chitosan and carboxymethylated chitosan. *J Appl Polym Sci* 2001; 79(7): 1324-35.
- [8] P. Madhavan (Ed.), *Chitin, Chitosan and their Novel Applications*, Science Lecture Series, CIFT, Kochi, 1992, p. 1.
- [9] P. Madhavan (Ed.), *Chitin, Chitosan and their Novel Applications*, Science Lecture Series, CIFT, Kochi, 1992, p. 1.
- [10] Park PJ, Je JY, Kim SK., Free radical scavenging activities of differently deacetylated chitosans using an ESR spectrometer. *Carbohydr Polym* 2004; 55(1): 17-22.
- [11] Peng C., Synthesis of crosslinked chitosan-crown ethers and evaluation of these products as adsorbents for metal ions. *J Appl Polym Sci* 1998; 70: 501-6.
- [12] Prashanth R, Tharanathan R., Chitin/chitosan: modifications and their unlimited application potential- an overview. *Trends Food Sci Tech* 2007; 18: 117-31.
- [13] Roberts G., *Chitin Chemistry*. London: Macmillan 1998.
- [14] Tharanathan RN, Kittur FS., Chitin: The Undisputed Biomolecule of Great Potential. *Crit Rev Food Sci Nut* 2003; 43(1): 61-87.
- [15] Xing R, Liu S, Guo Z, et al., Relevance of molecular weight of chitosan and its derivatives and their antioxidant activities in vitro. *Bioorg Med Chem* 2005; 13(5): 1573-7.